

# RT 710

## Hydraulic servo system



### Description

- complete model of a hydraulic servo control loop
- position control with adjustable load conditions
- hydraulic cylinder with directly mounted control valve
- vibration-damped mounting
- electronic servo amplifier
- GUNT software including oscilloscope and frequency generator

Servo systems are closed-loop control systems. In many industrial applications it is often required to convert small mechanical motions into a different motions with increased force. Hydraulic systems are particularly suitable for applications where large actuation forces are required. The RT 710 unit allows the operation of a hydraulic servo system to be investigated in detail. A carriage with a mass of 50kg is moved by a hydraulic cylinder. Additional springs and an adjustable hydraulic damper permit static and dynamic loads to be simulated. The displacement of the carriage is established using a potentiometric position sensor and compared against the reference variable. The control deviation is processed in a separate servo amplifier.

Depending on the direction of the deviation, a control valve is activated in forward or reverse direction, which in turn produces a corresponding movement of the hydraulic cylinder and the carriage.

All variables can also be tapped as voltage signals. The GUNT software contains among other features an oscilloscope, a frequency generator and a voltmeter. In dynamic processes, for example, the displacement signal can be represented on the oscilloscope. Via the software, the reference variable can also be applied to the system in the form of a voltage. This implies that, with the frequency generator, dynamic tests can be performed and the frequency response recorded.

The trainer is a mobile unit. Measuring devices can be housed in the built-under cabinet unit.

### Learning objectives/experiments

- familiarisation with the mode of operation of a hydraulic position control loop with adjustable load conditions
- reading and understanding circuit diagrams
- replacing springs and adjusting the damper
- influence of load and system pressure on control accuracy
- influence of the amplifier constants on the stability of the closed control loop
- recording the frequency response

# RT 710

## Hydraulic servo system

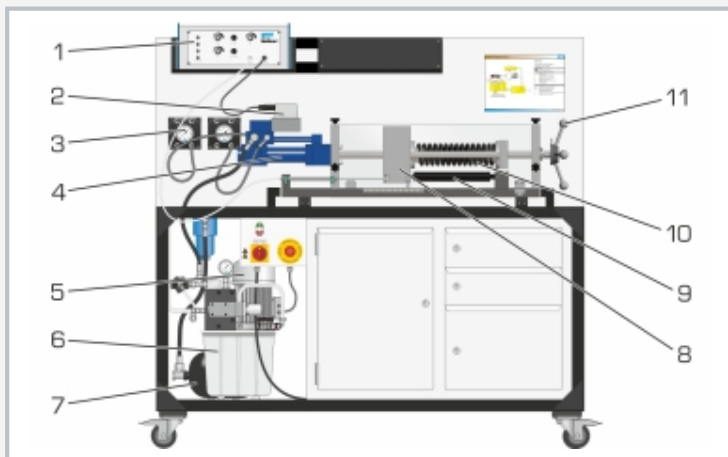

1 servo amplifier, 2 cylinder pressure manometer, 3 hydraulic cylinder with control valve, 4 switch box, 5 pump and oil tank, 6 carriage, 7 damper, 8 hand wheel for spring pre-tension, 9 springs

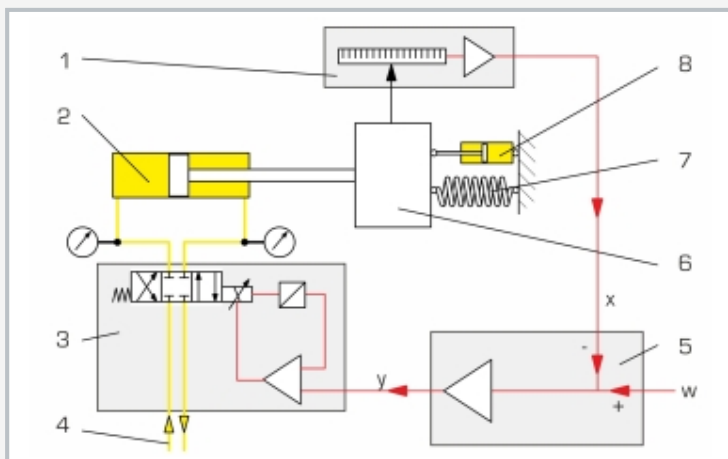

process schematic: 1 position sensor, 2 hydraulic cylinder, 3 control valve, 4 pressurised oil supply, 5 servo amplifier, 6 carriage, 7 spring, 8 damper; w reference value (setpoint), x controlled variable (actual value), y manipulated variable (manipulated value), yellow hydraulic oil

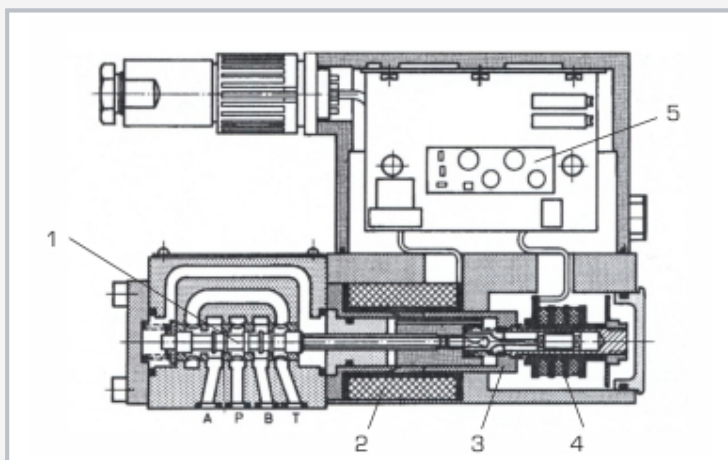

Control valve with position control capability: 1 control spool, 2 coil, 3 anchor, 4 displacement sensor, 5 control electronics

### Specification

- [1] self-contained training system of a complete hydraulic position control loop with adjustable loading conditions
- [2] oil circuit with hydraulic unit, hydraulic accumulator, 2 manometers, control valve and hydraulic cylinder to move a weighted carriage
- [3] operation of the electromagnetic control valve for position control by servo amplifier
- [4] servo amplifier with adjustable gain
- [5] all control variables available as voltage signals
- [6] potentiometric displacement sensor
- [7] adjustable load conditions on carriage using 2 springs with hand wheel and adjustable damping
- [8] low-friction ball bearing-mounted carriage
- [9] mobile steel profile trolley with built-under unit
- [10] GUNT software for data acquisition via USB under Windows 10

### Technical data

#### Hydraulic unit

- power output: 1,1kW
- flow rate: 4,3L/min
- head: 1500m
- tank capacity: 10L

#### Hydraulic accumulator capacity: 2L

Accumulator charging valve: max. 40L/min

#### Hydraulic cylinder

- piston diameter:  $d=40\text{mm}$
- stroke: 150mm
- mass moved: 50kg

#### Control valve NG6

- nominal flow rate: 24L/min
- activation:  $\pm 10\text{V}$

#### Potentiometric position sensor

- measuring range: 150mm
- output: 0 ...10V

400V, 50Hz, 3 phases; 400V, 60Hz, 3 phases

230V, 60Hz, 3 phases; UL/CSA optional

LxWxH: 1680x670x1600mm; Weight: approx. 420kg

### Required for operation

PC with Windows

### Scope of delivery

- 1 trainer
- 1 GUNT software + USB cable
- 1 set of accessories
- 1 set of instructional material