

TM 260.06

Pressure distribution in journal bearings

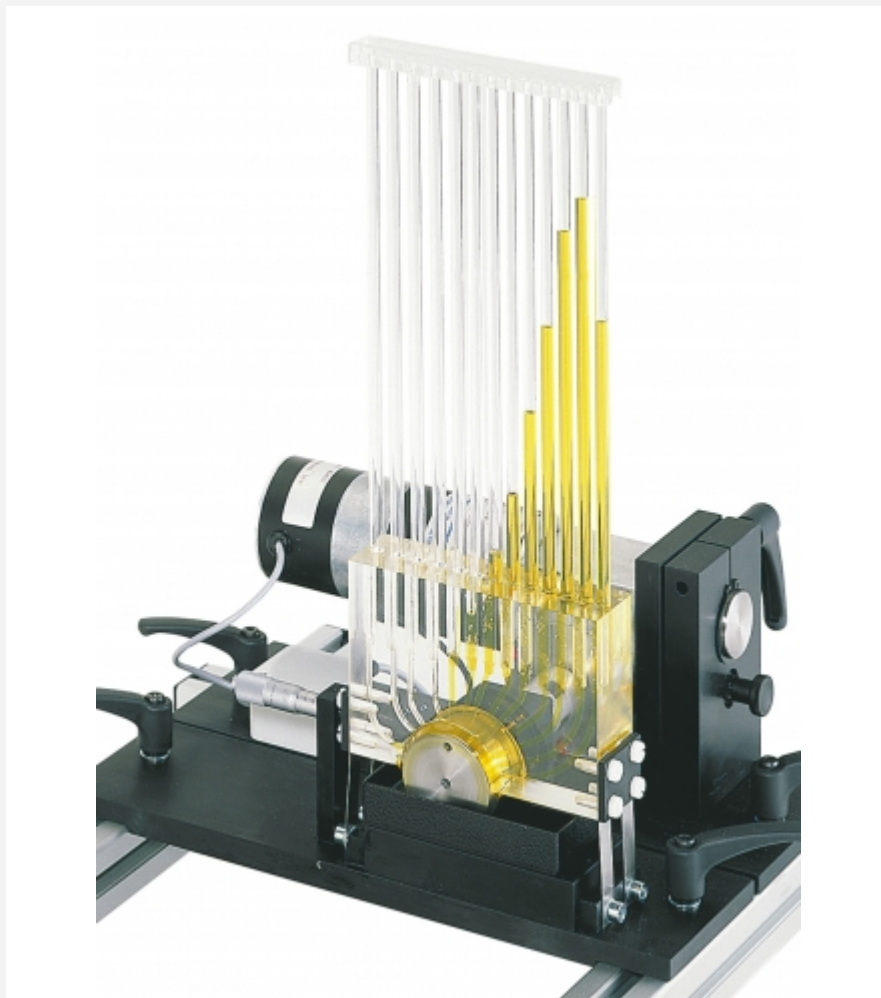

Learning objectives/experiments

- together with the drive unit
 - ▶ pressure distribution in the journal bearing depending on speed
 - ▶ pressure distribution in the journal bearing depending on load or bearing gap width
 - ▶ stability limit as a function of the gap width

Description

- depiction of radial pressure distribution in a journal bearing at different bearing gap widths
- bearing housing made of transparent plastic

The field of tribology covers all forms of friction. Dry, mixed and fluid friction all occur in journal bearings. Under operating conditions there is completely distinct fluid friction, so that the shaft and bearing shell are separated by a supporting lubricating film. The supporting function of the lubricating film can be described by the pressure distribution in the bearing gap.

The experimental unit TM 260.06 is used to visualise the radial pressure profile in the journal bearing with hydrodynamic lubrication.

To this end, the experimental unit contains an open bearing shell which only encloses a shaft half way and which simulates the journal bearing. The bearing shell is secured to two spring plates in such a way that it can be moved. Unlike real hydrodynamic journal bearings, the gap width can be adjusted via the radially moveable bearing housing by means of the spring plates and a micrometer screw.

The TM 260 drive unit is required in order to conduct experiments. The experimental unit is quickly and easily mounted on the frame of the drive unit with quick-action chucks. The shaft is driven by a clampable coupling between drive unit and gear unit. The display and control unit of the drive unit shows frictional force and speed and allows the continuous adjustment of the speed.

There are 13 measuring points around the circumference of the bearing shell to measure the pressure. The pressures are read off from a 13 tube manometers using the height of each column of liquid. The lubricant is supplied via an oil pan. The bearing shell is transparent, allowing close observation of the experiment.

TM 260.06

Pressure distribution in journal bearings

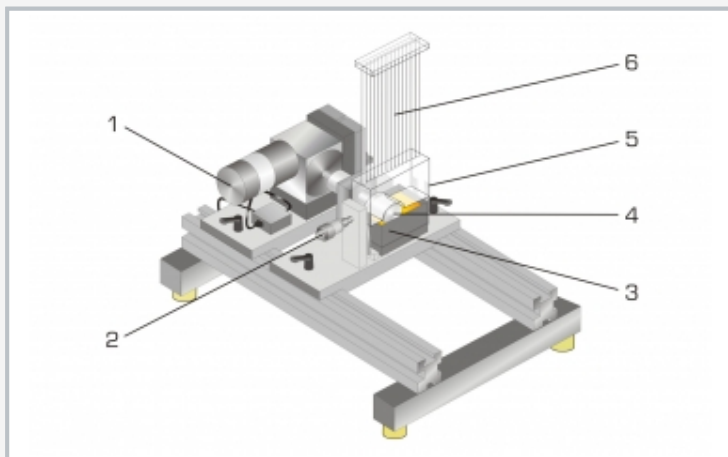

1 TM 260 base module, 2 bearing gap width adjustment, 3 oil pan, 4 shaft, 5 bearing housing with bearing shell, 6 tube manometers

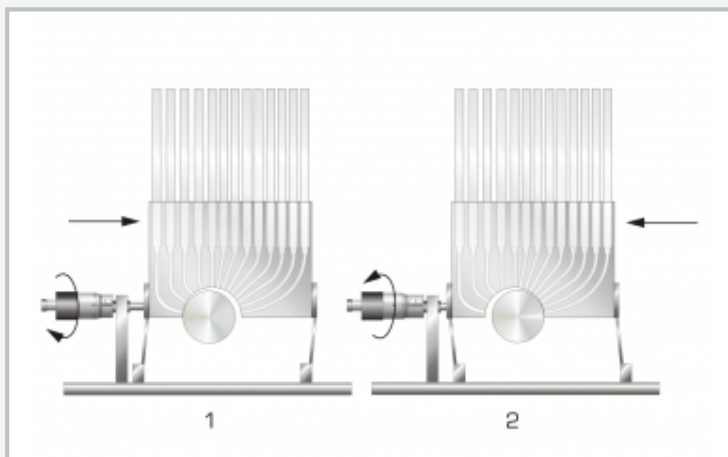

How adjustment of the bearing shell (bearing gap width) works: 1 bearing shell in right-hand position, 2 bearing shell in left-hand position

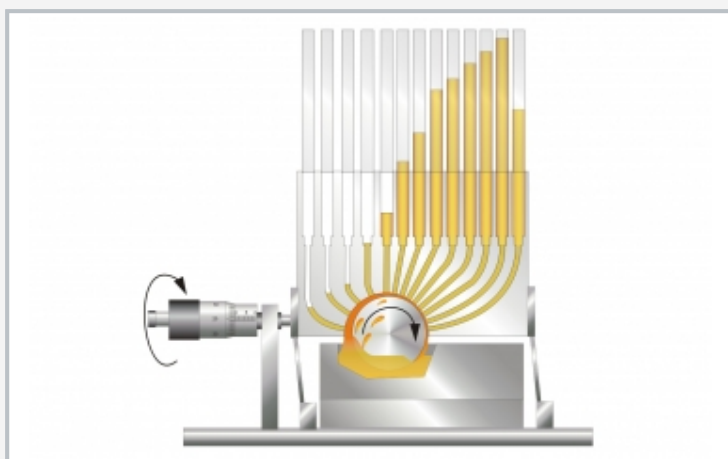

Pressure distribution over the bearing shell; pressure increases as the bearing gap decreases

Specification

- [1] demonstration and visualisation of the pressure distribution in a journal bearing with hydrodynamic lubrication
- [2] quick and easy assembly of the experimental unit on the frame of the drive unit
- [3] roller is driven by a clampable coupling between drive unit and gear unit
- [4] bearing housing is completely transparent
- [5] moveable bearing housing, adjustable bearing gap
- [6] 13 radial pressure measuring points on the bearing shell
- [7] radial pressure distribution indicated with 13 tube manometers
- [8] TM 260 base module required for operation

Technical data

Shaft

- diameter: 50mm
- length: 50mm
- material: stainless steel

Bearing shell

- diameter: 52,5mm
- bearing gap adjustable from: 0...2,5mm

Adjustment mechanism for bearing shell

- graduation: 0,01mm

Oil

- ISO viscosity grade: VG 32

Measuring ranges

- pressure: 360mm oil column
- speed: 0...200min⁻¹

LxWxH: 350x150x450mm

Weight: approx. 4kg

Scope of delivery

- 1 experimental unit
- 1 oil (0,5L)
- 1 set of instructional material

TM 260.06

Pressure distribution in journal bearings

Required accessories

040.26000

TM 260

Drive unit for tribological investigations