

## ET 352.01

### Solar heat for refrigeration



#### Learning objectives/experiments

- use of solar heat for refrigeration
- components of solar refrigerating plants according to the vapour jet method
- operation of a vapour jet compressor on a solar thermal flat collector
- optimisation of the operating point
- energy balances
- extended concept on the use of thermal solar plants
- energy management for solar thermal cooling systems

#### Description

- in combination with ET 352 and HL 313: use of solar heat as drive energy for a vapour jet compressor
- energy flow balances

With the increasing demand for refrigeration and air conditioning worldwide, the interest in alternative processes of refrigeration which can be supplied from renewable energy sources is also growing. One promising possibility is thermal processes. In these processes, thermal energy is used to generate cold.

ET 352.01 allows the vapour jet compressor from ET 352 to be operated with solar-generated heat from the HL 313 flat collector.

After sufficient solar thermal heating, the heat transfer fluid from HL 313 is pumped into the vapour generator of ET 352 by the pump from ET 352.01. The pump is operated via ET 352. ET 352 and HL 313 are connected by hoses.

The energy added from solar heat is determined by two temperature sensors and one flow rate sensor. The measured values are transferred to ET 352 and can be processed on a PC. They are also displayed directly on ET 352.01.

# ET 352.01

## Solar heat for refrigeration



1 feed/return line ET 352, 2 return line thermometer, 3 circulating pump, 4 feed/return line HL 313, 5 flow rate sensor, 6 feed line thermometer

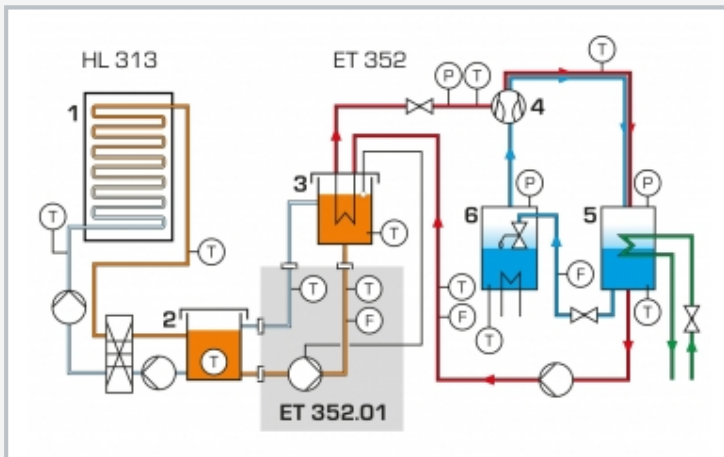

1 solar thermal collector, 2 heat accumulator, 3 vapour generator, 4 vapour jet compressor, 5 condenser, 6 evaporator; F flow rate, P pressure, T temperature; red: vapour cycle, blue: refrigeration cycle, green: cooling water, orange: warm heat transfer fluid, light blue: cold heat transfer fluid

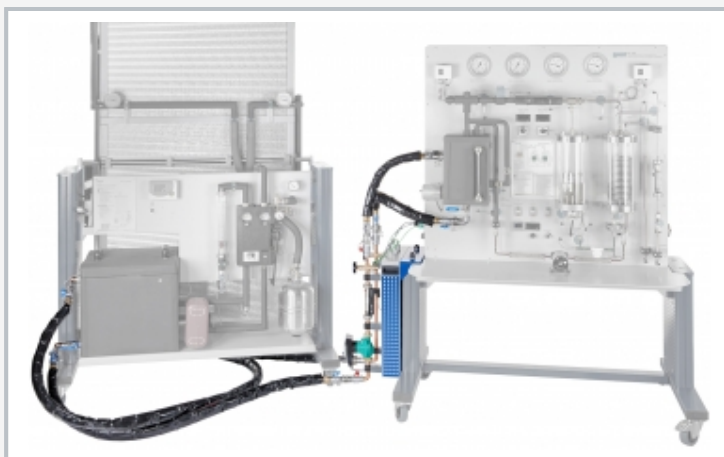

Functional experimental setup: HL 313 Domestic water heating with flat collector (left), ET 352.01 Solar heat for refrigeration (middle), ET 352 Vapour jet compressor in refrigeration engineering (right)

### Specification

- [1] supply of the vapour jet compressor in ET 352 with solar heat from the flat collector HL 313
- [2] pump for pumping the heat transfer fluid from HL 313 to the vapour generator in ET 352
- [3] feed line to the vapour generator with temperature and flow rate measurement
- [4] return line with temperature measurement
- [5] measured values transferred to ET 352 for further processing in the software
- [6] pump operated via ET 352
- [7] ET 352, HL 313 and ET 352.01 connected via hoses and quick-release couplings

### Technical data

#### Pump

- power consumption: 40W
- max. flow rate: 1 m<sup>3</sup>/h
- head: 4,8m

#### Measuring ranges

- temperature: 2x 0...120°C
- flow rate: 10...300L/h

LxWxH: 430x430x790mm

Weight: approx. 30kg

### Scope of delivery

- 1 experimental unit
- 1 set of hoses
- 1 set of instructional material

# ET 352.01

## Solar heat for refrigeration

### Required accessories

061.35200	ET 352	Vapour jet compressor in refrigeration
065.31300	HL 313	Domestic water heating with flat collector

### Optional accessories

065.31301	HL 313.01	Artificial light source
-----------	-----------	-------------------------