

CE 701

Biofilm process



2E

The illustration shows: supply unit (left) and trainer (right)

Description

- **aerobic biofilm processes: trickling filter**
- **practical experiments in laboratory scale**
- **concentration profiles**

Fixed biofilm processes are used in the biological treatment of wastewater. Trickling filters are based on these processes.

A pump transports the wastewater from the supply unit to the upper end of the trickling filter. The wastewater drops down on the trickling filter using a rotary distributor. In the trickling filter there is a fixed bed consisting of special carrier material. On this carrier material there is a thin layer of microorganisms (biofilm). While the wastewater trickles through the fixed bed, the microorganisms clean the wastewater by biological processes. The degradation of organic substances preferably takes place in the upper region of the trickling filter. In the lower region on the other hand, the oxidation of ammonium to nitrate (nitrification) is the predominant process. Subsequently, the wastewater flows into a collecting tank. Two pumps deliver a portion of the collected wastewater to the rotary distributor again (recirculation).

In the lower region of the trickling filter there are openings to allow aeration by natural convection. Alternatively, aeration can take place with a compressor.

To produce the biofilm, the trickling filter is first filled with the carrier material, wastewater and activated sludge. The activated sludge continuously discharging from the trickling filter sediments into a secondary clarifier. A pump transports the activated sludge back to the trickling filter. The trickling filter is aerated by a compressor. Over time, microorganisms present in the activated sludge settle on the carrier material, thus producing the biofilm.

The following flow rates are recorded and can be adjusted: wastewater, recirculation, aeration (with compressor). The speed of the rotary distributor can also be adjusted. Sampling points on the trickling filter allow concentration profiles to be recorded.

Activated sludge from a wastewater treatment plant is required for the experiments. To analyse the experiments we recommend analytical equipment for determining the following parameters:

- biochemical or chemical oxygen demand
- ammonium concentration
- nitrate concentration

Learning objectives/experiments

- functional principle of a trickling filter
- recording of concentration profiles
- creation of a stable operating state
- identification of the following influencing factors
 - ▶ flow rate of recirculation
 - ▶ volumetric loading of the trickling filter
 - ▶ surface loading of the trickling filter
- comparison of various carrier materials

CE 701

Biofilm process

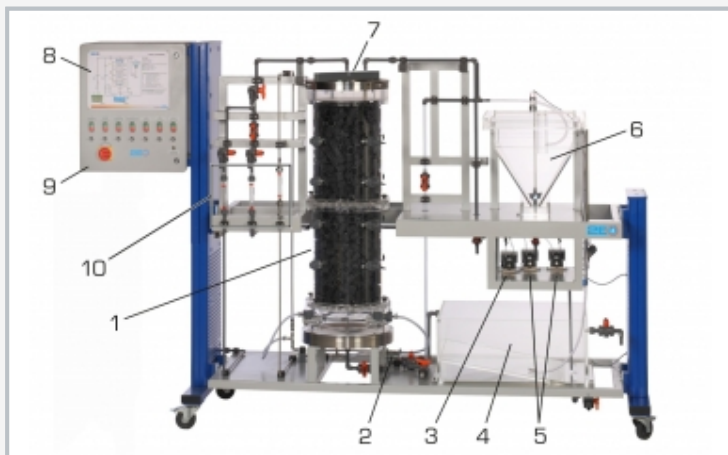

1 trickling filter, 2 compressor, 3 return sludge pump, 4 collecting tank, 5 circulation pumps, 6 secondary clarifier, 7 rotary distributor, 8 process schematic, 9 switch cabinet, 10 flow meter

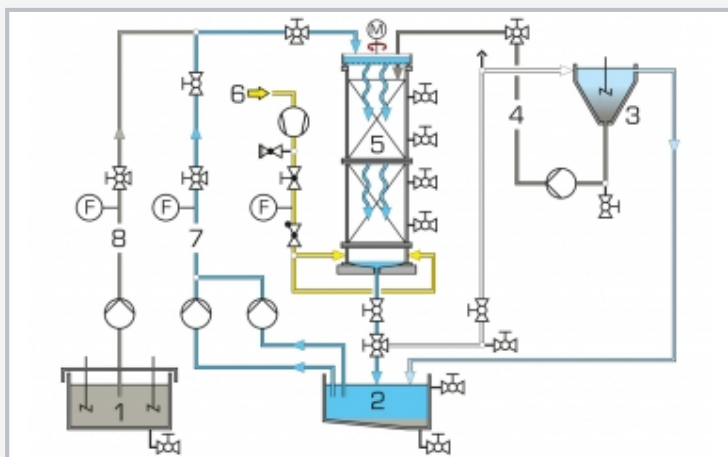

1 wastewater tank, 2 collecting tank, 3 secondary clarifier, 4 return sludge, 5 trickling filter, 6 air, 7 recirculation, 8 wastewater; F flow rate



carrier material for biofilm

Specification

- [1] aerobic biofilm process for the degradation of organic substances and for nitrification
- [2] transparent trickling filter with rotary distributor
- [3] speed of the rotary distributor finely adjustable
- [4] aeration of the trickling filter by natural convection or with compressor
- [5] recording of concentration profiles is possible
- [6] secondary clarifier with pump for transporting the return sludge
- [7] all relevant flow rates finely adjustable
- [8] separate supply unit with wastewater tank and two stirring machines
- [9] two different carrier materials made of HDPE

Technical data

Trickling filter

- diameter: approx. 340mm
- height: approx. 1000mm
- capacity: approx. 90L

Rotary distributor

- max. speed: approx. 2min⁻¹

Tanks

- wastewater tank: 300L
- collecting tank: 90L
- secondary clarifier: 30L

Flow rates

- wastewater pump: max. 25L/h
- circulation pumps: 2x max. 25L/h
- return sludge pump: max. 25L/h
- compressor: max. 600L/h

Carrier material

- specific surface: 180 or 300m²/m³

Measuring ranges

- flow rate:
 - ▶ 2...25L/h (wastewater)
 - ▶ 5...65L/h (recirculation)
 - ▶ 50...900L/h (aeration)

230V, 50Hz, 1 phase

230V, 60Hz, 1 phase

120V, 60Hz, 1 phase

UL/CSA optional

LxWxH: 1550x790x1150mm (supply unit)

LxWxH: 2870x790x1900mm (trainer)

Total weight: approx. 500kg

Required for operation

water connection, drain, activated sludge, substances for preparation of artificial wastewater

Scope of delivery

- 1 trainer
- 1 supply unit
- 1 set of hoses
- 1 set of tools
- 2 packing units of carrier material
- 1 set of instructional material