

# CT 400

## Test stand for four-cylinder engines, 75 kW

The series CT 400 equipment offers a wide range of experiments on industrial engines with a power output of up to 75 kW.

The complete test stand is made up of the CT 400 load unit and an engine. A choice of two water-cooled engines is available:

- 4 cylinder in-line engine, petrol
- 4 cylinder in-line engine, diesel

The engine can be connected to the load unit quickly and easily. The CT 400 load mechanism essentially consists of an adjustable air-cooled eddy current brake. The engines can be investigated in two modes:

- **torque control:** Manual adjustment of braking torque. The characteristic curve for the brake is changed, different full load points are approached and measurements are carried out depending on the speed.
- **speed control:** A controller keeps the speed constant, while the engine torque is increased. This allows different load points to be approached and measurements are carried out depending on the load.

An indicating system with software for data acquisition for the pressure curves in the engines and an exhaust gas analysis unit are available as accessories.



CT 400 Load unit, 75 kW, for four-cylinder engines

### CT 400

#### + test engine (CT 400.01 or CT 400.02) incl. software for data acquisition

- characteristic curves depending on speed and power output
- creation of heat balances at full and partial load
  - ▶ determination of imparted energy, effective usable power, amount of heat in cooler, amount of heat in exhaust gas losses, heat losses due to radiation and convection
  - ▶ representation in Sankey diagram
- comparison of diesel and petrol engines

### Extended range of experiments

with electronic indication including software for data acquisition with CT 400.09 + engine-specific pressure transducer with TDC sensor (CT 400.16 or CT 400.17)

and/or exhaust gas analysis with CT 159.02

#### CT 400.01

##### Four-cylinder petrol engine for CT 400

Water-cooled petrol engine with intake-manifold fuel injection, max. 55kW



#### CT 400.02

##### Four-cylinder diesel engine for CT 400

Water-cooled naturally aspirated diesel engine with direct injection, max. 41kW



#### CT 400.16

##### Pressure transducer and TDC sensor

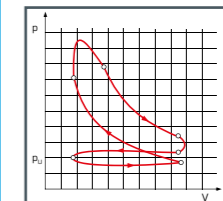

#### CT 400.09

##### Electronic engine indicating system for CT 400

Pressure measurement in the cylinder chamber of an internal combustion engine

- p-V diagram
- p-t diagram
- pressure curve during gas exchange
- determination of the indicated performance
- determination of mechanical efficiency

#### CT 400.17

##### Pressure transducer and TDC sensor



#### CT 159.02

##### Exhaust gas analysing unit

Measurement of the composition of exhaust gases (CO, CO<sub>2</sub>, HC, O<sub>2</sub>), the fuel/air ratio  $\lambda$  and the oil temperature of the engine.

## CT 400.01

### Four-cylinder petrol engine for CT 400



#### Learning objectives/experiments

- in conjunction with CT 400 load unit
  - ▶ plotting of torque and power curves
  - ▶ determination of specific fuel consumption
  - ▶ determination of volumetric efficiency and lambda (fuel-air ratio)
  - ▶ energy balances
  - ▶ overall engine efficiency

#### Description

- engine for setup of a test stand in conjunction with the CT 400 load unit
- closed cooling water circuit
- easy connection to the CT 400 load unit

In conjunction with the CT 400 load unit, the CT 400.01 engine is a complete engine test stand. The engine used here is a four-cylinder petrol engine with a controlled catalytic converter. It has its own closed cooling water circuit.

A solid welded frame on rollers carries the entire setup. Hazardous areas such as hot surfaces and rotating parts are covered with perforated plates. The connection to the brake is made via a rotationally elastic coupling with a jointed shaft. The engine is attached to the load unit by fasteners.

The engine is fitted with sensors that measure the temperatures and the cooling water flow rate. The switch cabinet contains all of the electronic equipment for managing the engine (factory set). On the switch cabinet are an ignition key, an operating time counter and warning lamps. Data is transferred between the CT 400 load unit and the engine via a data cable connecting the switch cabinets for the two units. A starter battery is also housed in the frame.

For safety reasons, the engine has been modified in a way that it only starts when it is connected to the load unit both mechanically and electrically.

## CT 400.01

### Four-cylinder petrol engine for CT 400

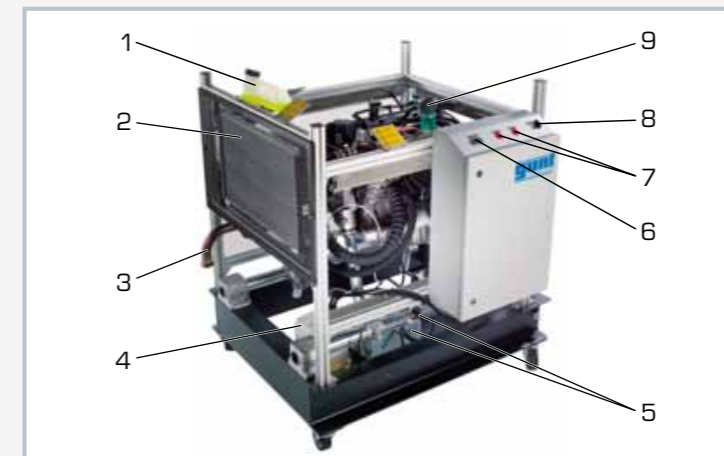

1 cooling water tank, 2 radiator with protective screen, 3 exhaust gas connection, 4 fuel tank, 5 battery with main switch, 6 operating time counter, 7 warning lamps, 8 key switch for ignition, 9 connection for engine feed air

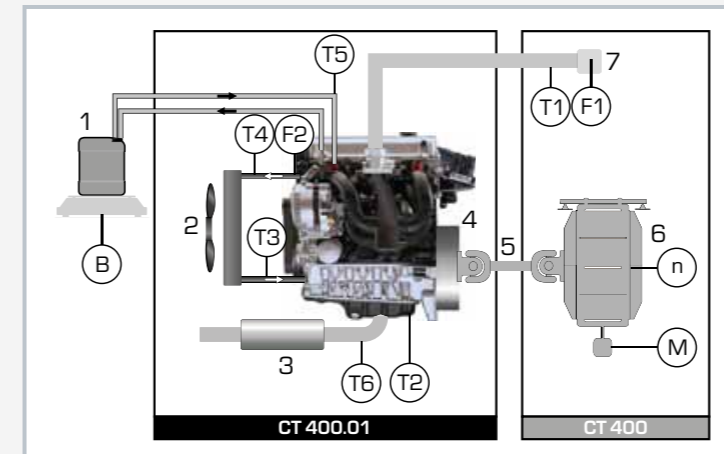

1 fuel tank, 2 radiator, 3 exhaust, 4 engine, 5 cardan shaft, 6 eddy current brake, 7 air inlet; n speed, M torque, B fuel consumption, volumetric flow rate: F1 air, F2 cooling water, temperatures: T1 intake air, T2 oil, T3 cooling water inlet, T4 cooling water outlet, T5 fuel, T6 exhaust gas

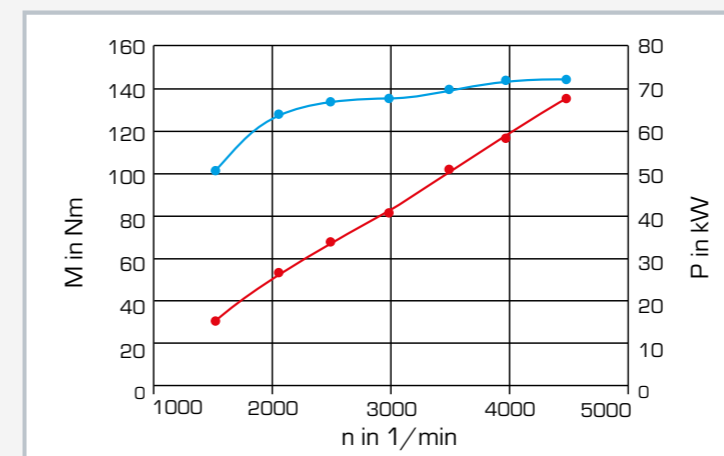

Power and torque characteristics of the engine  
n speed, M torque, P power

#### Specification

- [1] water-cooled four-cylinder petrol engine for setup of a test stand in conjunction with the CT 400 load unit
- [2] engine flexibly mounted on mobile frame
- [3] force transmission to brake via rotationally elastic coupling and jointed shaft
- [4] engine complete with fuel supply (tank, pump, hose) and cooling water circuit
- [5] sensors for cooling water flow rate and temperatures (exhaust gas, cooling water, fuel, oil)
- [6] transfer of measured data via data cable from switch cabinet to CT 400 switch cabinet
- [7] switch cabinet with warning lamps (oil pressure, alternator failure), operating time counter and ignition key

#### Technical data

- Water-cooled four-cylinder petrol engine
- displacement: 1596cm<sup>3</sup>
  - bore: 79mm
  - stroke: 81,4mm
  - power output: max. 75kW at 4800min<sup>-1</sup>
  - torque: max. 155Nm at 4150min<sup>-1</sup>
  - compression ratio: 11:1
  - ignition sequence: 1-3-4-2

Starter battery: 12V  
Fuel tank capacity: 5L  
Fuel: petrol 95 Octane  
Engine oil: SAE 5W-30

230V, 50Hz, 1 phase  
230V, 60Hz, 1 phase  
230V, 60Hz, 3 phases  
LxWxH: 1200x1120x1340mm  
Weight: approx. 400kg

#### Scope of delivery

- 1 engine, built into frame
- 1 manual